

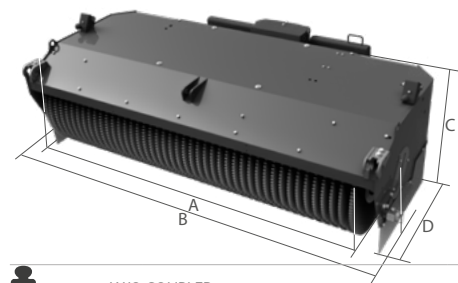

**NB: AT THE TIME OF ORDER, PLEASE NOTIFY THE VOLTAGE OF THE ELECTRICAL SYSTEM (12-24 V)**

IT IS PERFECT FOR THE MAINTENANCE AND CLEANING OF OPEN SURFACES, FLOORS, INDUSTRIAL HALLS AND STREETS THAT REQUIRE A HIGH-LEVEL CLEANING.



	MOD.	EASY SWEEPY R160	EASY SWEEPY R180	EASY SWEEPY R210	EASY SWEEPY R230
A	MM (IN)	1600 (62,99)	1800 (70,86)	2100 (82,67)	2300 (90,55)
B	MM (IN)	1850 (72,83)	2050 (80,70)	2350 (92,51)	2550 (100,39)
C	MM (IN)	800 (31,4)	800 (31,4)	800 (31,4)	800 (31,4)
D	MM (IN)	1300 (51,18)	1300 (51,18)	1300 (51,18)	1300 (51,18)
	KG (LB)	330 (727,52)	350 (771,61)	375 (826,73)	395 (870,82)
	MM (IN)	600 (23,62)	600 (23,62)	600 (23,62)	600 (23,62)
	N.	33 + 2	37 + 2	43 + 2	48 + 2
	MAX. L/MIN (GAL/MIN)	70 (18,49)	70 (18,49)	70 (18,49)	70 (18,49)
	MAX. BAR (PSI)	250 (3625,94)	250 (3625,94)	250 (3625,94)	250 (3625,94)



14/8 PIN CONNECT\*

\* THE CONNECTOR TYPE YOU REQUIRE MUST BE INDICATED AT THE TIME OF ORDERING, OTHERWISE THE 14-PIN CONNECTOR WILL BE SUPPLIED AS STANDARD.

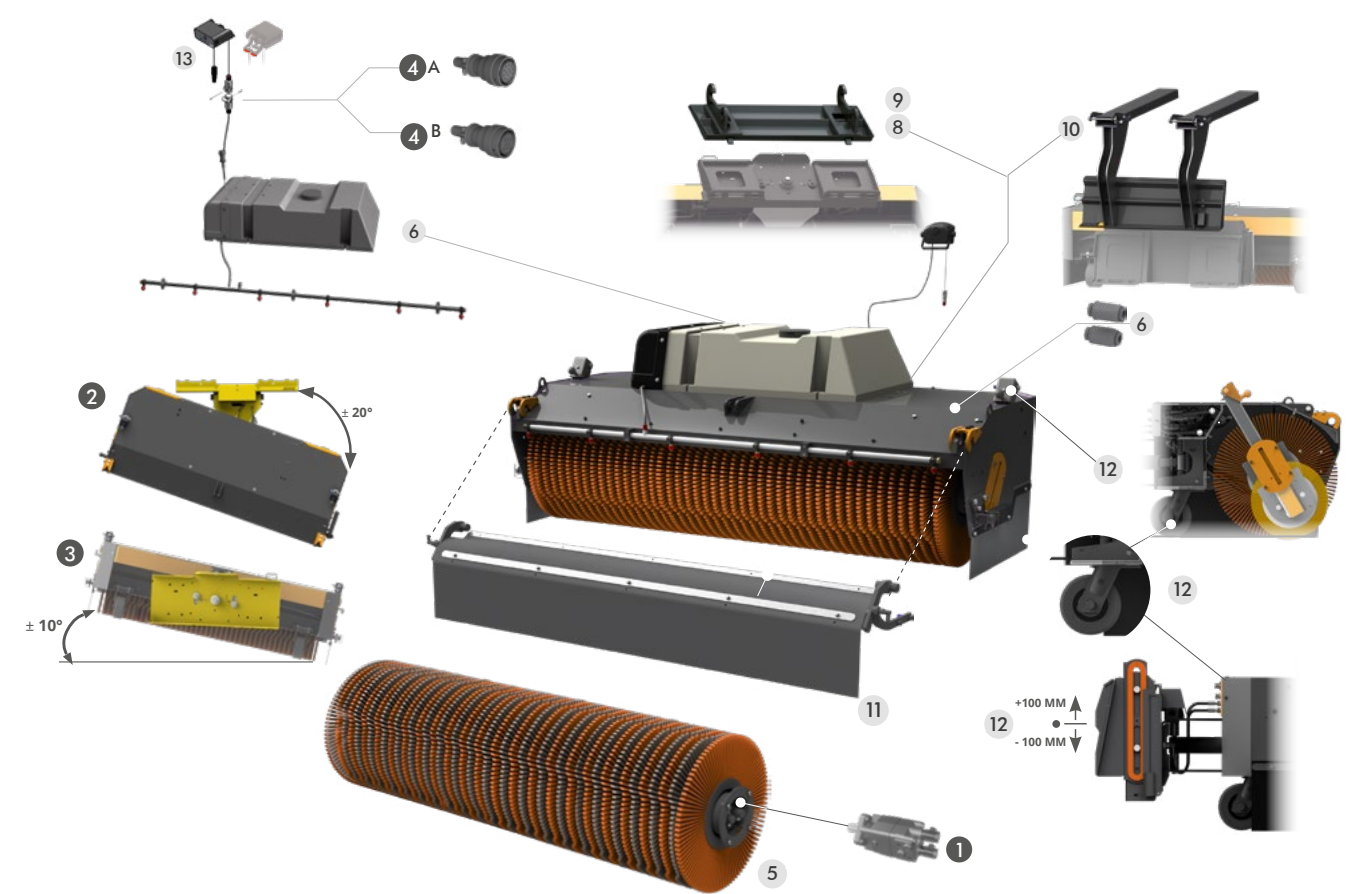

### STANDARD TECHNICAL FEATURES

- ENGINE WITH SQUARE FLANGES AND DISK GEARBOX**  
SHAFT WITH INTEGRAL MOTOR, NOT SUITABLE FOR HIGH FLOW SYSTEM
- ANGLE SIDE HYDRAULIC TILTING ADJUSTMENT OF ± 20°**  
IT ALLOWS THE HYDRAULIC ADJUSTMENT OF THE TILTING ANGLE UP TO A MAX. OF +/-20° ON EACH SIDE.
- TILT - HORIZONTAL MECHANICAL TILTING ADJUSTMENT OF ±10°**  
IT ALLOWS THE MECHANICAL ADJUSTMENT OF THE WORKING PLANE TILTING ANGLE UP TO A MAX. OF +/- 10° ON EACH SIDE.
- 14 PIN HD36-18-14SE (A) OR 8 PIN HD36-18-8SE (B) CONNECT**  
SUPPLIED SEPARATELY IF CLEAR INFORMATION ABOUT PLUG WIRING IS NOT PROVIDED

**NB : THE EQUIPMENT IS SUPPLIED COMPLETE WITH PIPES AND CONNECTIONS**

### OPTIONAL

- PPL+STEEL BRUSH KIT**  
RECOMMENDED FOR THE CLEANING OF PARTICULARLY ABRASIVE SURFACES.
- DUST-CONTROL SYSTEM WITH TANK AND PUMP**  
PRESSURIZED WATER SYSTEM WITH TANK FOR THE CONTROL OF DUSTS PRODUCED DURING THE WORKING CYCLE. SPRINKLERS ARE POSITIONED INSIDE AND OUTSIDE THE SWEEPER.
- FLOWRATE REDUCERS**  
MANDATORY ON HIGHFLOW MACHINES OR WITH OILRATE HIGHER THAN 70 L/MIN.
- ARTICULATED LOADERS, BACKHOE LOADERS AND TELEHANDLER HANDLERS HITCH**
- ARTICULATED LOADERS HITCH**
- COUPLING FRAME FOR FORKS**
- ADJUSTABLE FRONT SKIRT**
- COMPACT FLOATING SYSTEM KIT 200 MM**  
IT ALLOWS THE SWEEPER TO FOLLOW THE GROUND AND BETTER THE FINAL RESULT. DESIGNED FOR MACHINES SUCH AS LOADERS AND TELESCOPIC LOADERS. IT IS SUPPLIED WITH ROLLER PRESSURE ADJUSTMENT SYSTEM AND WHEELS KIT.
- ELECTRIC KIT**